

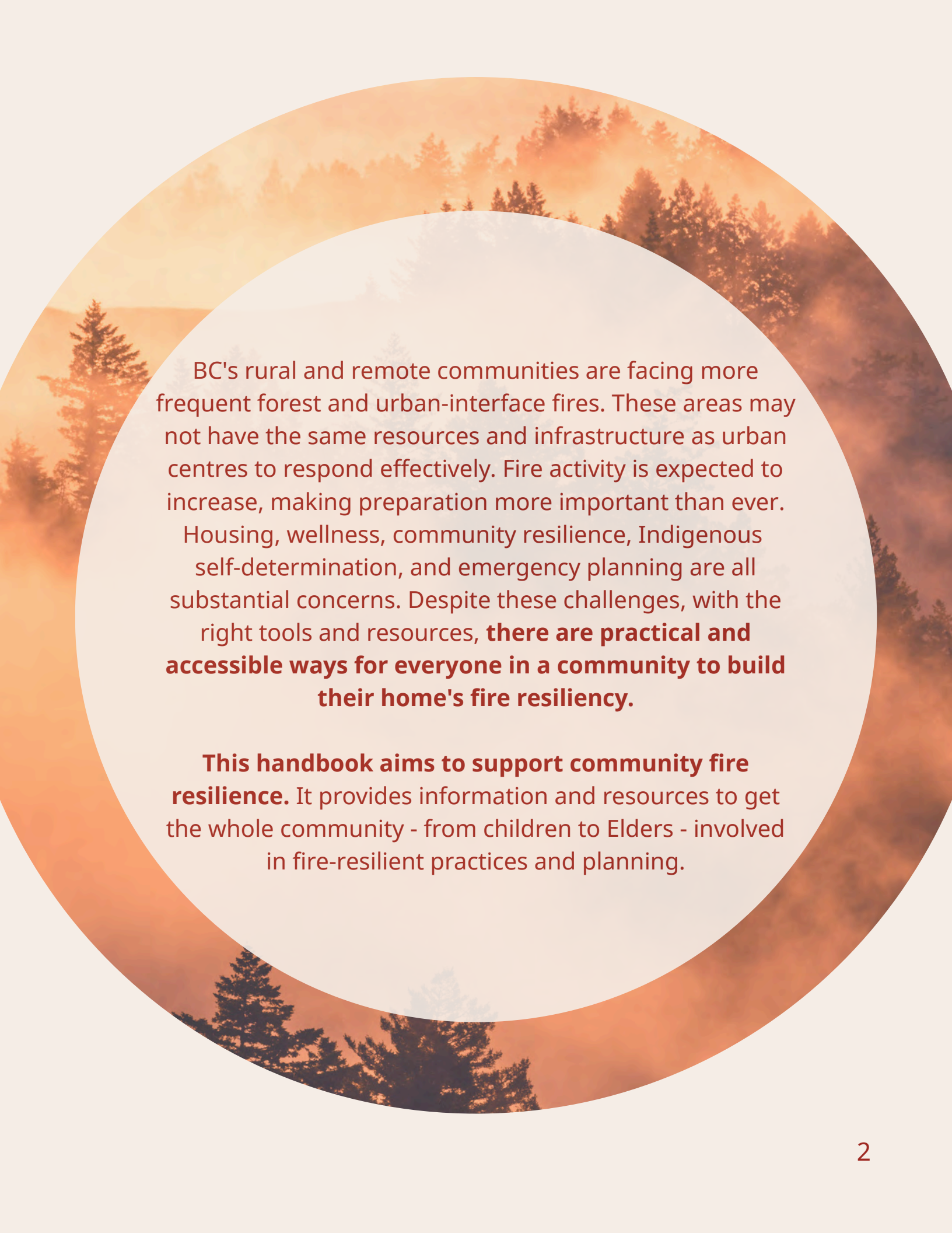

COMMUNITY FIRE RESILIENCE

2026

Community Resource Handbook



BC's rural and remote communities are facing more frequent forest and urban-interface fires. These areas may not have the same resources and infrastructure as urban centres to respond effectively. Fire activity is expected to increase, making preparation more important than ever. Housing, wellness, community resilience, Indigenous self-determination, and emergency planning are all substantial concerns. Despite these challenges, with the right tools and resources, **there are practical and accessible ways for everyone in a community to build their home's fire resiliency.**

This handbook aims to support community fire resilience. It provides information and resources to get the whole community - from children to Elders - involved in fire-resilient practices and planning.

Chapters



Community Planning ----- 10



Fire Primer ----- 26

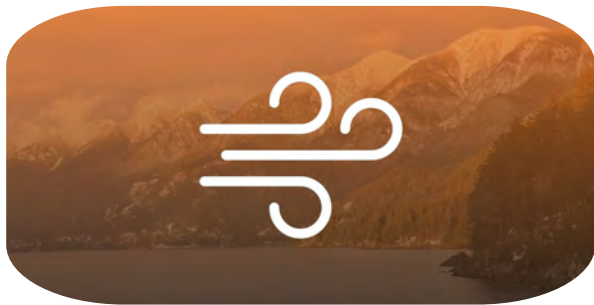

Air Quality ----- 30



Housing & Building ----- 37

An interactive chapter sharing capacity & funding resources is published on the website only.



Acknowledgements



This handbook is part of the research project **Building Climate Resilience in Rural & Remote Communities**. The project is centred around collaborations that bridge climate strategies and policies in British Columbia with Indigenous and community-driven expertise. It focuses on low-carbon resilience in housing, technical systems, and community planning.



PICS

Building Climate Resilience in Rural & Remote Communities is funded through the Pacific Institute for Climate Solutions (PICS).

Learn more about PICS and its work at climatesolutions.ca.



As a step towards Indigenous self-governance, the First Nations Housing and Infrastructure Council (FNHIC) delivers housing and infrastructure programs for First Nations in British Columbia. They provide comprehensive services that promote self-determination, organizational growth, and transformation, ensuring that no First Nation is left behind.

The project team would also like to thank the following people for their guidance and support in completing this project:

- The many attendees of our webinar series and focus groups, who saw this project come into reality and offered feedback along the way.
- **Gil Davies**, West Moberly First Nations building manager, and West Moberly Chief and Council, who contributed so thoroughly through their comments, advice, and consistent participation in our workshops.
- **James Bourget** (RDH Building Science) for imparting his knowledge and guidance on fire resilient building materials at our webinars.
- **Niki Lindstrom** for her dedication as a collaborator and champion on this project.
- **Patrick Michell** (Nlaka'pamux Nation Elder; former Rebuild Director for Lytton First Nation) for his willingness to share his support, guidance, and knowledge.

The Fire Resilient Communities Handbook would not be the tool that it is today without the contributions, kindness, and expertise of those who collaborated and contributed to this project. Thank you.

FireSmart, Intelli-feu and other associated Marks are trademarks of the Canadian Interagency Forest Fire Centre Inc.



Defining Resilience

Fire resilience is distinct to each community, meaning every community may need distinct supports and tools to support their resilience. A community's infrastructure, residents, capacity, and values will all influence fire resilience. Resilience facilitates recovery, empowering individuals to support each other and strengthen their community's capacity to respond to the ongoing, urgent challenges posed by wildfires.

The handbook aims to:

- Be **engaging** for everyone, at every age.
- Serve as a **resource guide** for housing, maintenance, capital, infrastructure and other managers, residents, and homeowners.
- Provide **practical information** on fire mitigation strategies.
- Be a source of **capacity-building** ideas, activities, and programs for communities.

This handbook is grounded in the principle of building resilience for future generations, drawing on the knowledge and experiences of the generations who came before us. Building fire-resilient communities for future generations should be rooted in past, present, and future innovations. The resources in this guide aim to acknowledge and honour Indigenous knowledges, building styles, and governance.

Community Fire Resilience

Community fire resilience begins with systems of shared responsibility. Every generation plays a role, and by working collectively, communities can create holistic systems that protect the intersecting risks associated with fire.

Community resilience includes practices that are embedded into many aspects of community life, governance, and planning. As a result, community resilience is interwoven with other risks, concerns, and the wellbeing of the community. The Fire Resilience Wheel aims to capture these related topics. It can be customised to more precisely represent individual communities and Nations' priorities.

The inner segments of the wheel represent broad, overlapping aspects of fire resilience. The outer segments are examples of those broad categories and were chosen through community engagement sessions. They are not exhaustive.



Community resilience includes practices that are embedded into many aspects of community life, governance, and planning. As a result, community resilience is interwoven with other risks, concerns, and the wellbeing of the community. The Fire Resilience Wheel aims to capture these related topics.



Community resilience includes practices that are embedded into many aspects of community life, governance, and planning. As a result, community resilience is interwoven with other risks, concerns, and the wellbeing of the community. The Fire Resilience Wheel aims to capture these related topics. Try filling out your community's priorities!

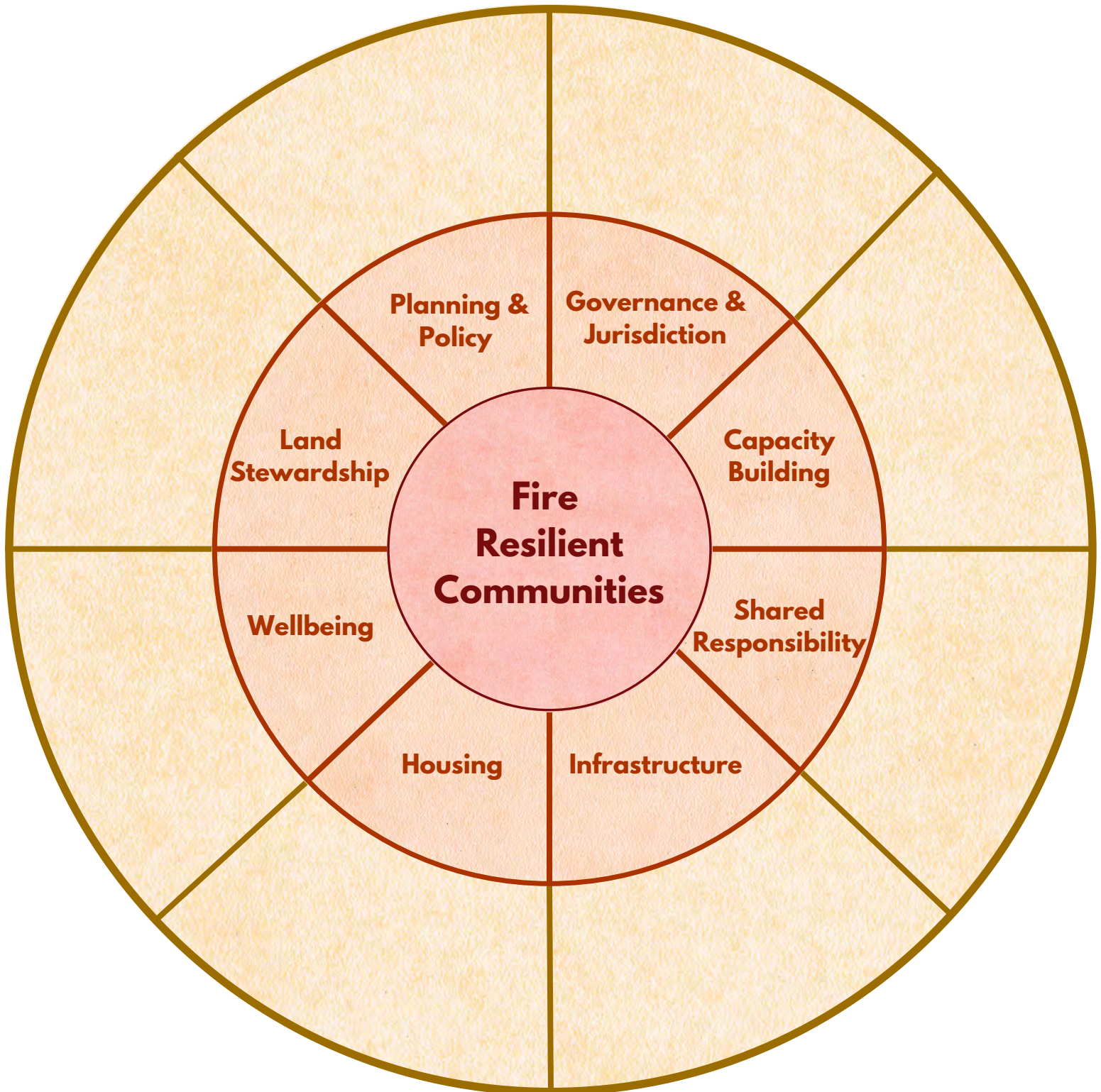

Community resilience includes practices that are embedded into many aspects of community life, governance, and planning. As a result, community resilience is interwoven with other risks, concerns, and the wellbeing of the community. Try filling out your community's values and priorities in this blank wheel.

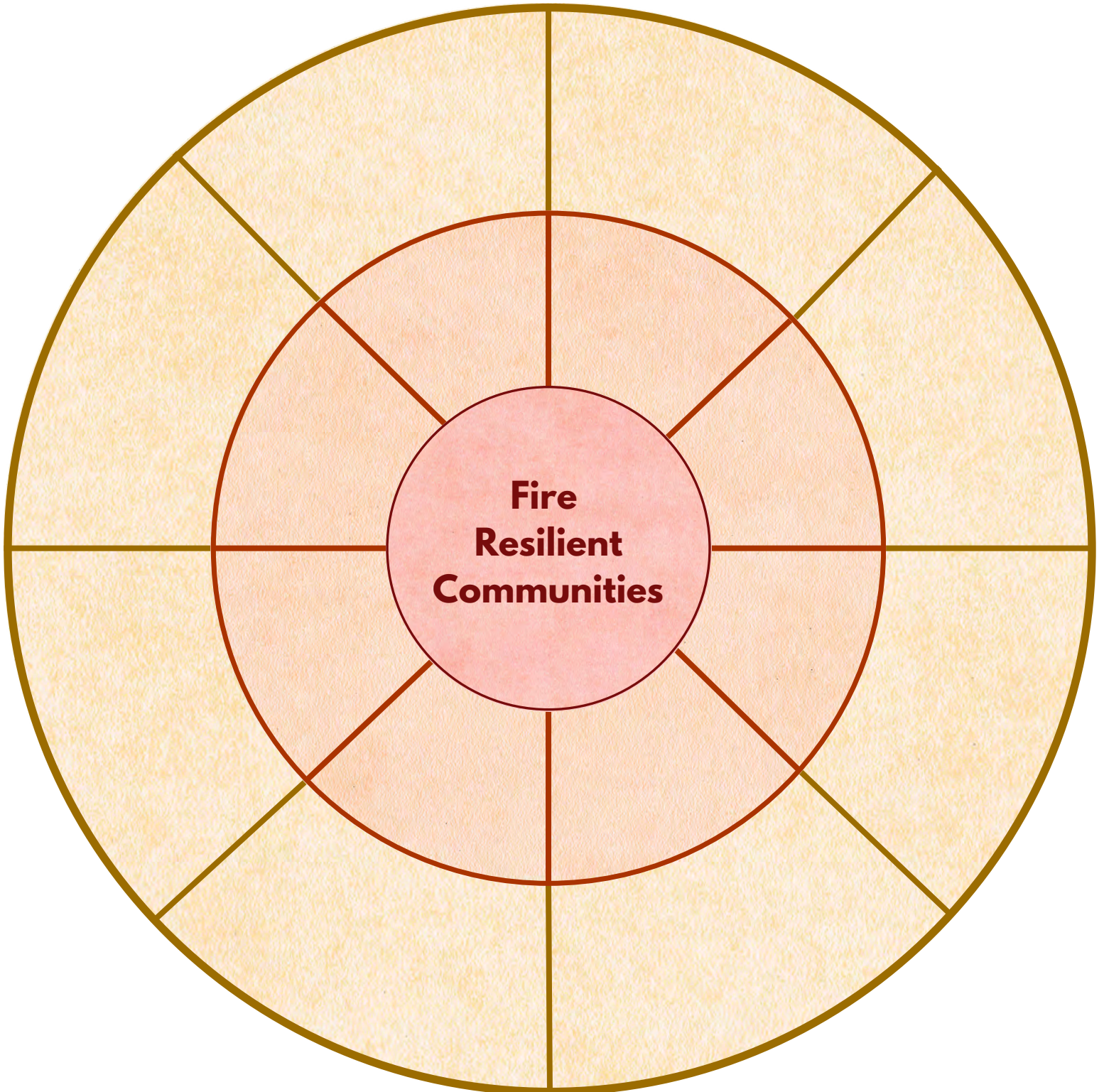

Community Planning Kit

This section provides resources to help both households and communities prepare for fires.

Resources available in this section include:

- A calendar of important dates related to fire resilience and preparedness;
- Contact sheets for urgent situations (standard letter size, pocket-size for wallets, and one specifically for kids/youth);
- A checklist of items to include in a 'go bag' for emergencies;
- Community mapping activities to support:
 - Community asset mapping.
 - Evacuation route planning.



FIRE PREPAREDNESS CALENDAR - BRITISH COLUMBIA

<p>January</p> <ul style="list-style-type: none"> <input type="checkbox"/> Community planning sessions & workshops 	<p>February</p> <ul style="list-style-type: none"> <input type="checkbox"/> Tool maintenance <input type="checkbox"/> Community tool shed fundraiser 	<p>March</p> <ul style="list-style-type: none"> <input type="checkbox"/> Tree maintenance event <input type="checkbox"/> Ignition Zone 1 planning: clear debris and gutters 	<p>April</p> <p><i>Fire season may begin</i></p> <ul style="list-style-type: none"> <input type="checkbox"/> FireSmart Home Assessments <input type="checkbox"/> Community event to assemble and distribute Go Bags
<p>May</p> <ul style="list-style-type: none"> <input type="checkbox"/> Continue yard and home maintenance tasks <input type="checkbox"/> Community lawn mowing event 	<p>June</p> <p>Refresh and review:</p> <ul style="list-style-type: none"> <input type="checkbox"/> Go Kits <input type="checkbox"/> Evacuation plans <input type="checkbox"/> Shelter-in-place plans 	<p>July</p> <ul style="list-style-type: none"> <input type="checkbox"/> Community outreach and FireSmart maintenance 	<p>August</p> <ul style="list-style-type: none"> <input type="checkbox"/> Community outreach and FireSmart maintenance
<p>September</p> <ul style="list-style-type: none"> <input type="checkbox"/> Community outreach and FireSmart maintenance 	<p>October</p> <p><i>Fire season is likely to be coming to a close</i></p> <ul style="list-style-type: none"> <input type="checkbox"/> Yard and home maintenance tasks 	<p>November</p> <ul style="list-style-type: none"> <input type="checkbox"/> Community recovery and planning for the year ahead 	<p>December</p> <ul style="list-style-type: none"> <input type="checkbox"/> Community fire resilience groups and workshops

The calendar above has examples of community events and maintenance tasks. Every community will differ in seasonality, landscape, planning, and resources. FireSmart™ practices should be maintained year-round.

FireSmart, Intelli-feu and other associated Marks are trademarks of the Canadian Interagency Forest Fire Centre Inc.

Contact Sheets

Collecting key contacts ahead of time can aid in rapid response to fires.

As applicable, have the contacts for the following individuals/groups available:

- Fire Department;
- Housing Manager;
- Emergency Services;
- Fire Resilience Steward (a community leader who promotes fire resilience and supports fire preparedness activities);
- Personal emergency contact(s).

The contact sheets from the handbook can be printed to fill by hand or filled out using a PDF viewer. You could also save these contacts on your phone if possible.

Note: to print out the contact sheet at the correct size, set the Scale (%) in the print settings to 'Actual' instead of 'Fit to Printable Area'



FIRE SAFETY: KEY CONTACTS

Role	Name	Contact Information
Local emergency service		
Non-emergency fire service		
Housing manager		
Urgent health service		



FIRE SAFETY: KEY CONTACTS

Role	Name	Contact Information
Local emergency service		
Non-emergency fire service		
Urgent health service		
Trusted Adult*		
Trusted Adult		
Trusted Adult		

*A trusted adult might be a family member, close friend, community elder, teacher, or anyone else you would feel safe and able to contact in an urgent situation.

FIRE SAFETY: KEY CONTACTS

Role	Name and Contact Information
Local emergency service	
Non-emergency fire service	
Housing manager	
Urgent health service	

'Go' Bags

Useful for more than just fires, a 'go' bag is a collection of supplies a household keeps ready in a portable kit in case of emergency. They can save time and stress in case of a sudden evacuation order or other urgent event.

In addition to the general list of items included within the checklist (next page), go bags should be adapted to fit a household's health, cultural, and personal needs.



As examples:

- Identification may include a passport, driver's license, health card, birth certificate, permanent resident card, visa, and/or status card.
- The First Nations Health Authority's example kit, made by their Vancouver Coastal Health Emergency Management Team, includes Skwxwu7mesh Uxwumixw canned sockeye salmon, plant medicines, and a sage & cedar bundle. Different nations may have culturally significant plants and/or medications that could be included in a kit.



Fire Preparedness Tip: In addition to packing supplies, Technical Safety BC has [information on preparations you should consider for electrical and gas safety](#). Unplugging non-essential electrical appliances, turning off valves, shutting off the water, and clearing combustible material near propane storage tanks can minimise the impact of fires. If your natural gas is supplied by Fortis BC or Pacific Northern Gas, do not shut off your natural gas. If you are on propane or your gas is supplied by another entity, shut of the main gas supply.

Emergency Kits

Emergency preparedness kits will have many of the same items as a go bag, but are for sheltering in place during an emergency situation. In addition to the items in a go bag, they should include:

- Food for at least three days. In remote areas with limited access and exit routes, food for 7-10 days is ideal.
- A one-week supply of water, which should be replaced once a year.
- Garbage bags and towelettes.
- Lantern and fuel for light. Be sure that any fuel is stored outside and away from a heat source.
- Bush cooking stove for cooking outside. Be sure that any fuel is stored outside and away from a heat source.

Supply lists for emergency kits have been produced by the [Government of BC](#) and the [Red Cross](#) (page 11 of the PDF).

Fire Preparedness Tip: Once you've put together your kits, it's important to check on them regularly. You'll want to ensure that any perishables haven't spoiled, that all equipment still works (e.g., you may need to replace old batteries), and that your information is up-to-date. Set yourself a reminder on your calendar if you use one!

GO BAGS

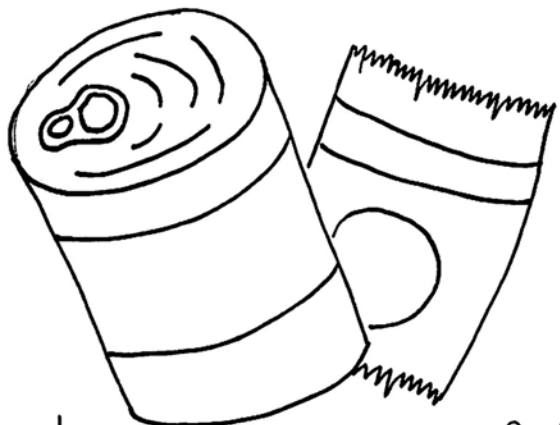

3-7 days of non-perishable food



4L of water / person

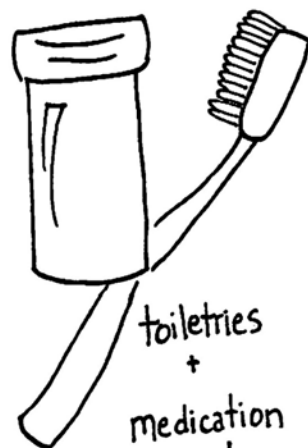

toiletries + medication



flashlight

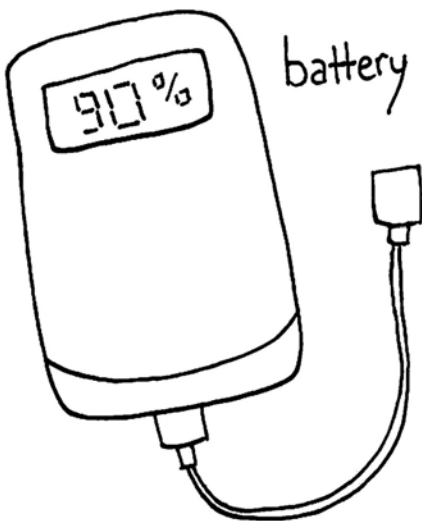

battery



radio



whistle

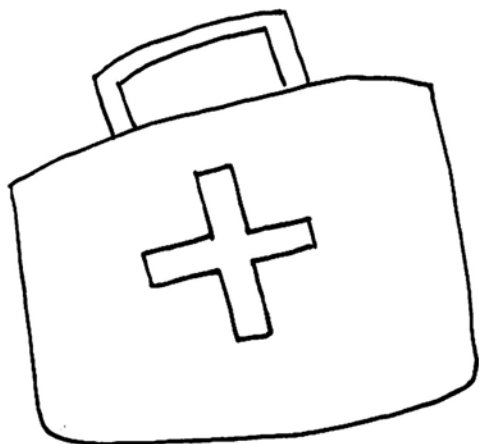

first aid kit



ID, insurance, plans, key contacts



masks (in case of smoke / dust)

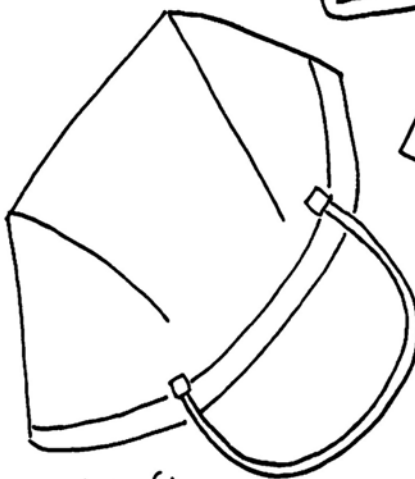

blankets

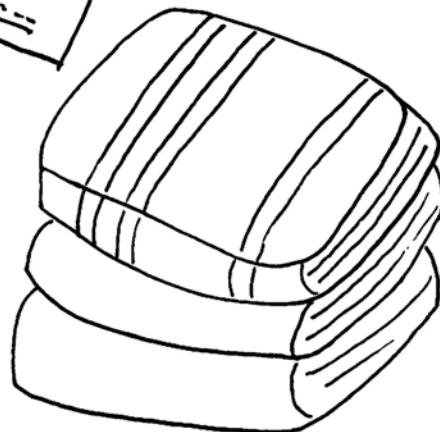

Community Tool Sheds

Enacting fire resilient strategies often requires access to physical tools. A community tool shed, or tool library, can provide community members with access to tools they might not otherwise have, which can help everyone maintain a fire resilient community. Community tool sheds often operate like a library, with sign out sheets and membership cards to keep track of shared tools. They may come from collaborations with the local public library, community center, or through grassroots initiative.

Potential items that might be in a community shed include:

- Buckets
- Gardening or hedge clippers
- Lawn mowers and grass trimmers
- Rakes
- Shovels
- Wheelbarrows

The Toronto Tool Library is an excellent example of a potential model for a community tool shed.



Community Asset Mapping

When planning for emergencies, an inventory of critical infrastructure can be useful to identify coordinated evacuation points, potential hubs for emergency services, and which buildings should be prioritised when funding upgrades for climate resilience. For example, critical infrastructure buildings might be the first to receive formal FireSmart assessments.

Which locations are identified as critical infrastructure is community-dependent and should be informed by community values and priorities. Potential critical infrastructure types include:

- Animal welfare shelters;
- Cultural, community, and recreation centres;
- Fire halls;
- Halls or other large gathering places;
- Libraries;
- Museums and archives;
- Operations centres;
- Schools and other educational facilities;
- Youth centres and preschools;



Evacuation Routes

Fires may require communities to evacuate quickly and on very short notice. Mapping out potential evacuation routes ahead of time can aid with safe and lower-stress evacuations.

Fire Preparedness Tip: If you have animals in your care (horses, chickens, livestock etc.), you may want to consider special arrangements for their relocation. Some regional districts have emergency plans for livestock (e.g., Alberni-Clayoquot Regional District's [emergency plan for farms](#), the Regional District of Bulkley-Nechako's [resources](#)) that may be applicable or helpful when planning for non-commercial animals. Additionally, registering for a [Premises ID](#) with the provincial government allows emergency responders to properly document who to reach out to during emergencies.

Map Your Community: Community Assets and Evacuation Routes

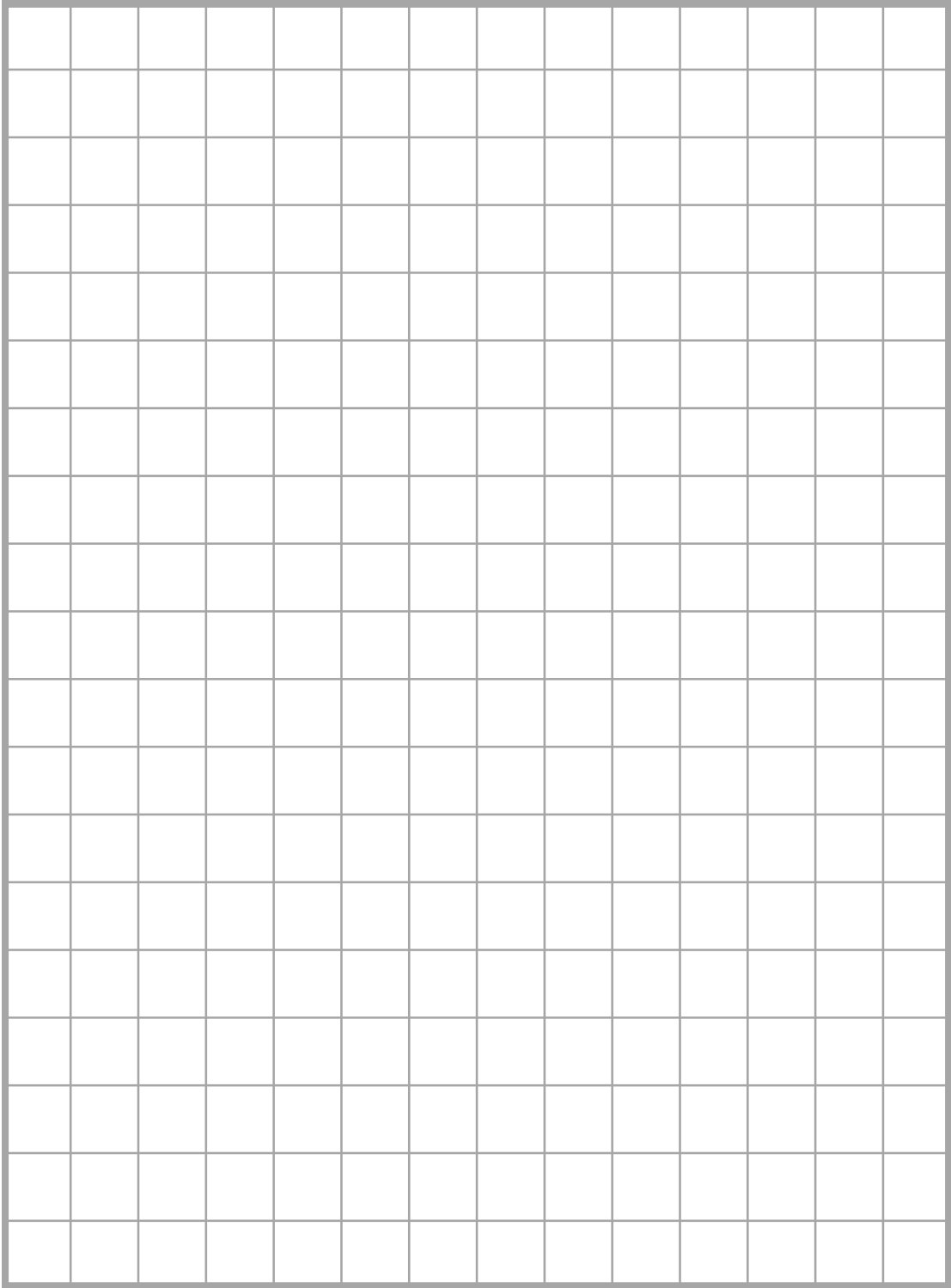

Guidelines:

1. Start with **key landmarks** like your home, landscape features etc.
2. Identify fire halls, cooling centres, and/or **safe shelter sites** that you could evacuate to
3. Identify the location of **exit points** (i.e., roads out of town)
4. Some areas within a community may be more **vulnerable** to fire than others i.e., if they have dry, uncleared vegetation that could serve as fuel. Identify these areas to ensure your evacuation routes avoid them if possible, as they may be blocked off or other inaccessible in the event of a fire.
5. Based on the location of your home and key sites for potential evacuation, determine and draw out viable, **safe evacuation routes**.

Notes

Other Resources for Community Planning

Three Features of a Wildfire-Ready Community



Author: Intact Centre on Climate Adaptation at the University of Waterloo
Published 2023.

This one-page document provides three ways to plan a wildfire-resilient community through protecting structures, designing the community to reduce risk, and proactively designing emergency responses.

Wildland Urban Interface Community Preparedness Digital Tool



Author: National Indigenous Fire Safety Council
Published 2023.

This tool identifies 18 community roles and/or groups who have a part to play in wildfire preparedness, outlining what they should do before, during, and after a wildfire. Each role is represented by an icon designed by Anishinaabe Onyota'a:aka artist Tsista Kennedy. This one-page document provides three ways to plan a wildfire-resilient community through protecting structures, designing the community to reduce risk, and proactively designing emergency responses.

The recommendations within the tool are based on a report from the University of Waterloo, which draws from case studies of wildfire preparation and management in First Nations communities.

Other Resources for Community Planning

The Fires Awakened Us – Wildfire Report



Author: Jocelyn Stacey, Crystal Verhaeghe, and Emma Feltes, produced for the T̓silhqot'in Nation
Published 2019.

This report reflects on the T̓silhqot'in Nation's experiences of the 2017 wildfire season. As shared by the Nation's Tribal Chairman, Nitsil'in Joe Alphonse, "we hope this report can be used to improve emergency management in other First Nation communities while also maintaining their rightful jurisdiction". Community planners may find the calls to action on pages 12 to 20 of the document particularly useful.

Wildfires? Here's what you need to know about electrical and gas safety.



Author: Technical Safety BC
Published 2021.

This short blog post provides guidance for homeowners and businesses to maintain electrical and gas safety if you are on evacuation alert or evacuation order. There are also precautions to take when returning home after an evacuation.

Fire Primer: How do fires spread?

Understanding fire behaviour is the first step in preventing its spread. When forest fires reach residential areas, they become *interface fires*. Mitigating the spread of interface fires requires community planning, home and yard maintenance, and following FireSmart™ practices.

Fire Triangle: Fire requires fuel, heat, and oxygen to start and spread. By clearing surface fuels throughout communities and ladder fuels against structures, the spread of interface fires can be mitigated. Fuels include anything that could catch fire: vegetation, firewood, wood chips, leaf piles, fuel tanks, and trees are all examples of fuels.

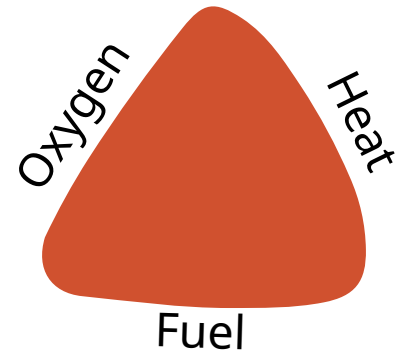

There are three ways fires spread:

Embers

Embers are burning debris carried by wind. They can travel up to 8 km.

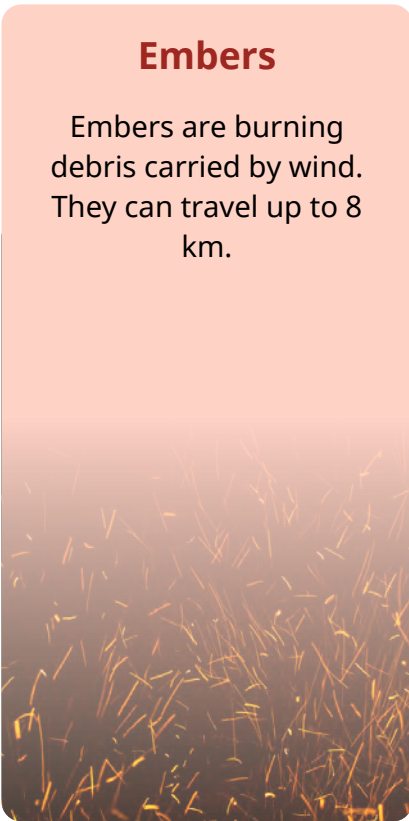

Radiant Heat

Intense heat from a nearby fire can ignite a structure.

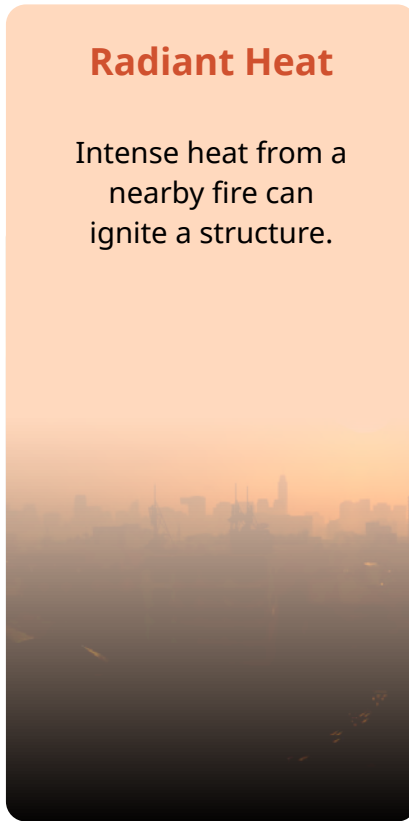

Direct Flame

Fire from a nearby structure or tree may transfer to a building directly.

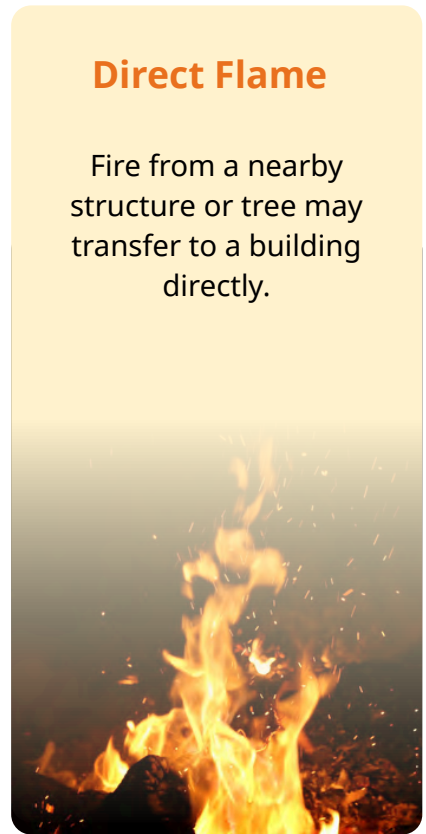

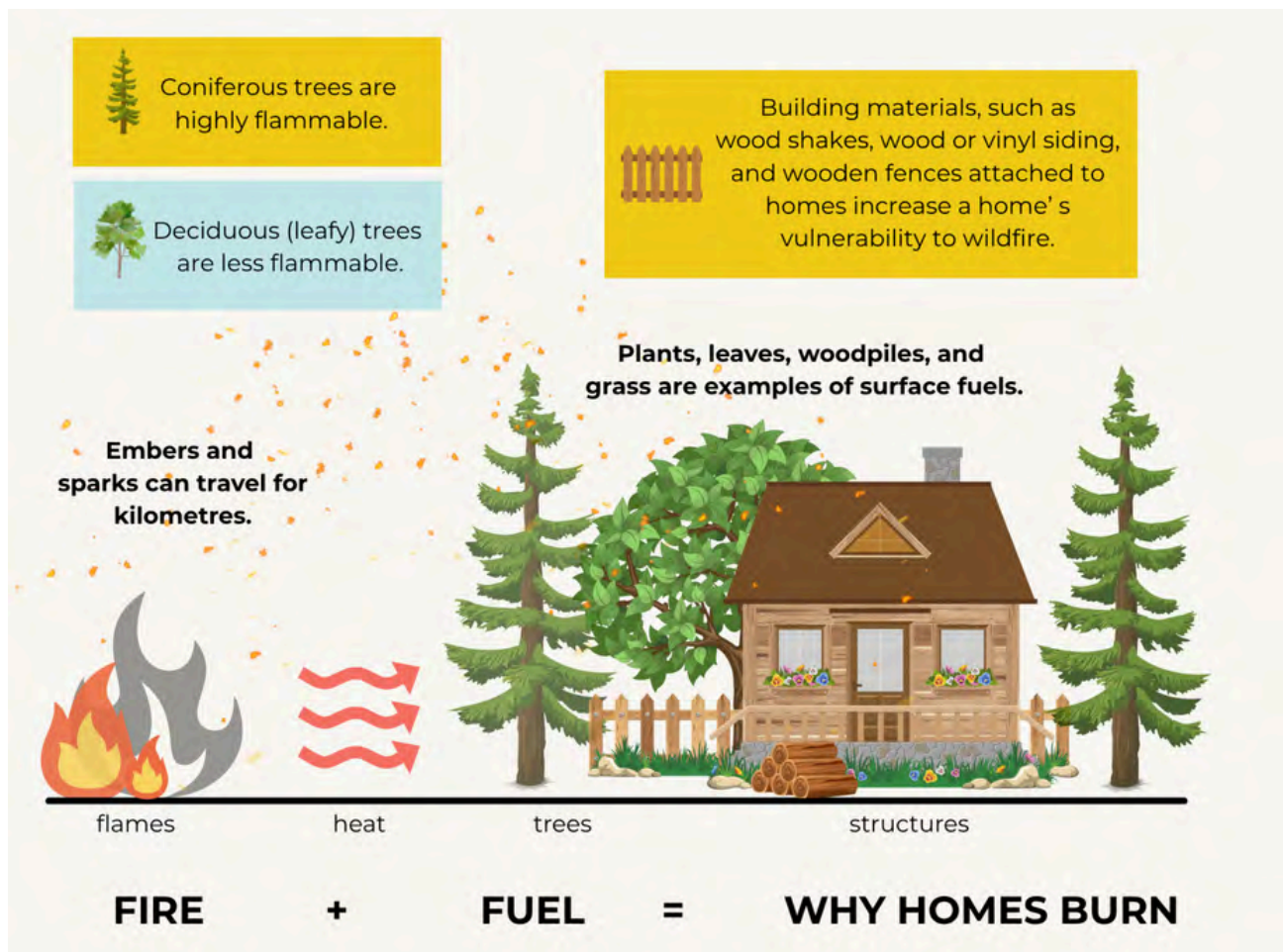

Fires can spread due to trees, surface fuels, and structures made of flammable building materials. Graphic made by Alexandria Jones (FireSmart™ Canada).

Why does the fire triangle matter?

In many rural households, it's common practice to store firewood against the exterior wall of the home. This can pose a fire risk because the combination of the wood (fuel) and gaps between logs (space for oxygen) can quickly ignite if an ember from a fire, even just a small campfire, falls into the gap. Decks with wooden boards with a >3mm gap pose a similar hazard, especially if leaves and other dry matter that could fuel a fire are underneath the deck.

The other recommendations to mitigate fire spread in the following section also aim to minimise the potential of embers becoming larger, dangerous fires.



Home Ignition Zones

Careful planning and maintenance for each zone can improve your home's resilience to fire and mitigate spread. This section provides some suggestions of important tasks to maintain fire safety in each zone. Additional recommendations are provided in the [FireSmart Begins at Home Guide](#).



Immediate: 0 - 1.5m

Priority: reduce the chance of ignition if an ember lands near your home by reducing fuel sources.

- Clear debris. Nothing should be stored against the house.
- Roofs and gutter cleaned and equipped with <3mm mesh.
- Chimneys equipped with spark arrestors.
- Decks cleared and free of gaps.

Intermediate: 1.5 - 10m

Priority: manage the area to mitigate the risk of fire transmission to the home.

- Lawns mowed shorter than 10 cm.
- Foliage and trees tended from overgrowth.
- Fire resistant foliage and trees when possible.
- No placement of fuel tanks, firewood, or fire pits.

Extended: 10 -30m

Priority: reduce the intensity of any potential fires.

- Trees pruned and thinned from the bottom up.
- Space trees at least 3 m apart.
- Ensure safe and visible exits for emergency services.
- Plan collaboratively with neighbours to steward shared extended zones.

HOW DOES FIRE SPREAD?

- HOME IGNITION ZONES

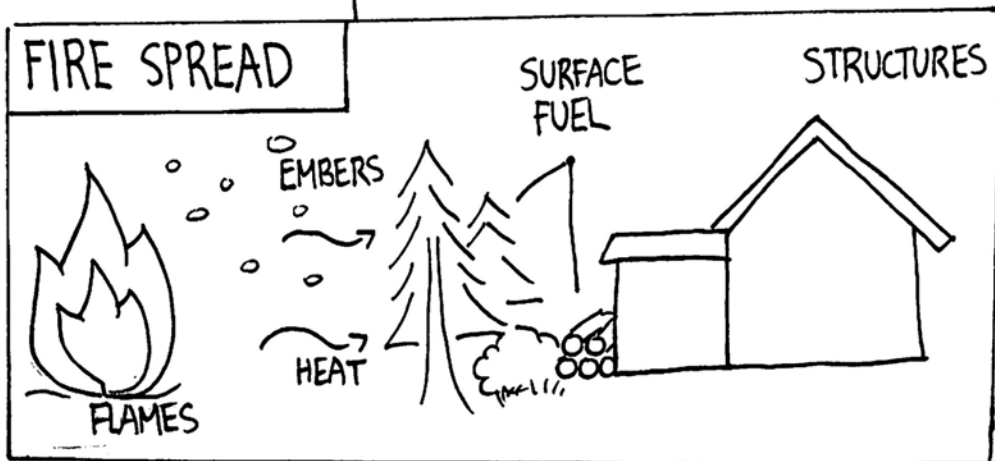
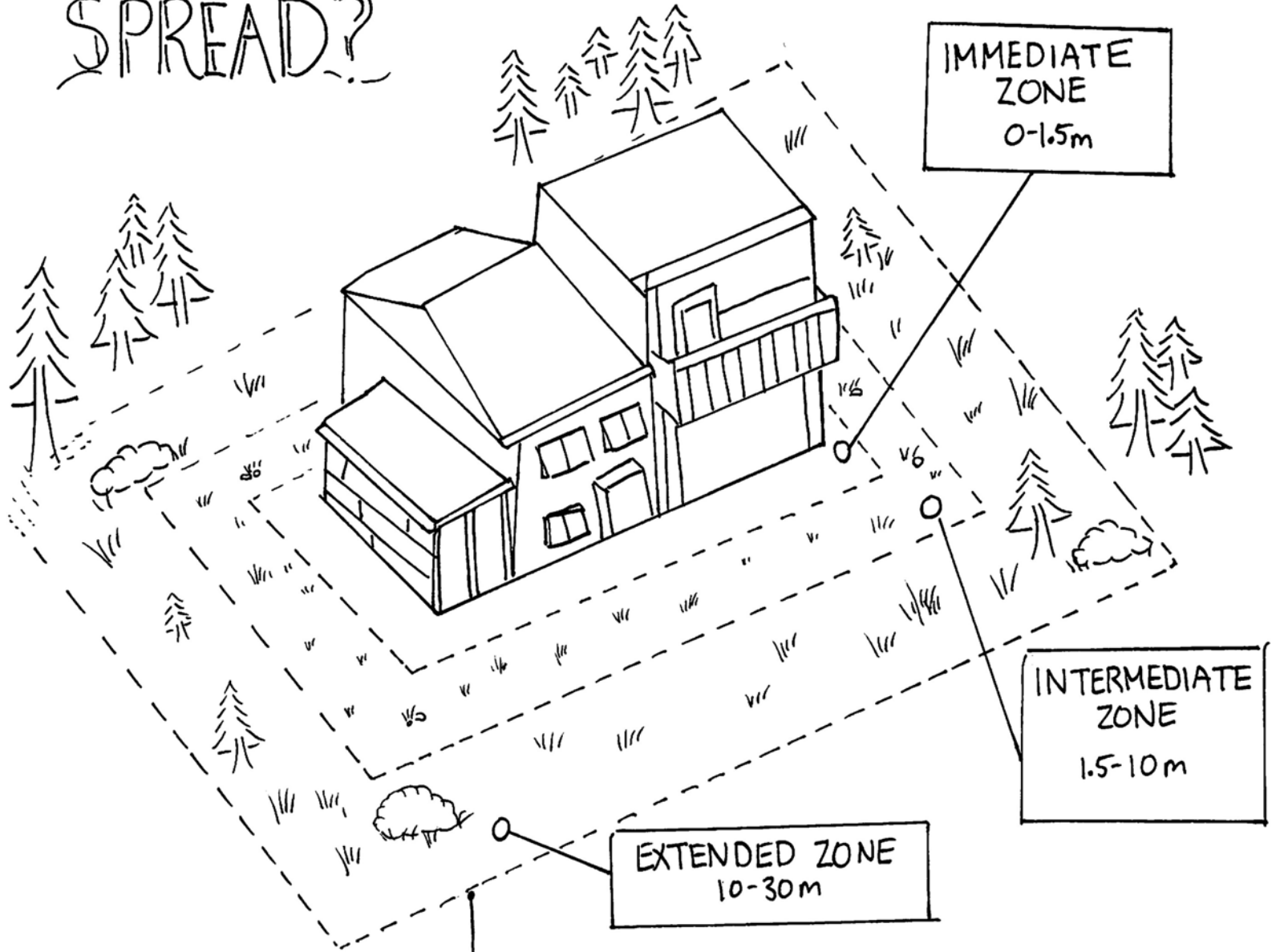

Graphics adapted from FireSmart Canada

Air Quality Primer

Communities across British Columbia are finding practical and creative ways to protect themselves from wildfire smoke. From building your own portable air purifiers to establishing dedicated clean-air spaces in community gathering spaces, there are simple and cost-effective measures that you and your community can take to protect your well-being and health.

Why does wildfire smoke matter?

Wildfire smoke can:

- Cause immediate and long-term adverse health effects.
- Travel long distances and can last for days to weeks.
- Infiltrate homes through cracks, vents, doors, windows, chimneys etc.

Among the many pollutants in wildfire smoke, tiny airborne particles called fine particulate matter (PM2.5) pose the greatest risk to human, animal, and plant health. These extremely small particles (smaller than 2.5 micrometers) can travel deep into the lungs and even enter the bloodstream. [Extensive research](#) shows that PM2.5 can reduce lung function and cause serious health problems, including bronchitis, cognitive decline, heart failure, and premature death.

Who is most at risk?

Those at higher risk may include:

- Older adults, infants, and pregnant individuals.
- Outdoor workers, athletes.
- Individuals living in rural or remote areas.
- Individuals with pre-existing heart, lung, or chronic health conditions.
- Individuals with lower socio-economic status (e.g. income, housing, education).



There is no safe level of exposure to wildfire smoke. Even healthy adults risk adverse health effects after brief exposure.



How do I monitor air quality?

Canada uses the Air Quality Health Index (AQHI) to measure overall health risk from air pollution on a scale from **1 (low risk) to 10+ (very high risk)**.

To monitor current or forecasted air quality near you, useful resources include:

- Weather forecast apps, available on most mobile devices.
- [WeatherCan App](#) for real-time updates and alerts.
- [FireSmoke Canada](#) for smoke forecasts.
- [Purple Air Monitor Maps](#) for localised, real-time air quality readings.
- [BC Air Quality Warning Alerts](#) to subscribe to notifications during times of degraded air quality.

Forecasts may not always accurately reflect local conditions. Trust your instincts - **if smoke is noticeable through sight or smell, please take precautions.**



How do I remove particulate matter from smoky air?

Using a HEPA (High Efficiency Particulate Air) filter is one of the most effective tools for protecting yourself from fine particulate matter.

- If possible, use an air purifier with a **HEPA and carbon filter** to remove both smoke particles and odors.
 - Learn how to make a low-cost [Do-it-Yourself air filter](#) through a tutorial developed by the SFU Breathe Project.
- Ozone-generating “air purifiers” can worsen indoor air quality. The California Air Resources Board [keeps a list](#) of 'purifiers' that intentionally omit ozone.
- Replace filters regularly if they appear dark or dusty.
- Vacuums with a HEPA filter may help prevent stirring up indoor particles.

Need help choosing an air purifier? Try this simple [step-by-step guide](#)!

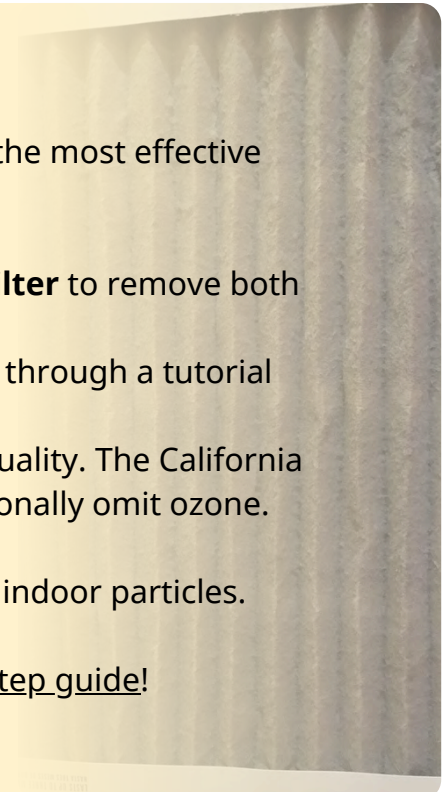

How does smoke infiltrate homes, and what can individuals do to stop it?

For most people, fully sealing a home against wildfire smoke is difficult and expensive, especially in older buildings. A more practical option is to designate a **clean air room**: a space such as the bedroom or basement designed to provide protection from excess smoke inhalation.

The room should preferably include:

- A **portable air purifier with a HEPA filter** to remove particles.
 - No filters? Block vents and other gaps with towels or cloth to limit smoke indoors.
- Extra HEPA air filters. Remember, not all filters are made equally. HEPA filters are certified to remove 99.97% of particles 0.3 microns or larger.
- A portable air cleaner.
- An **activated carbon filter** to reduce odors and gases.
- **Taped or sealed windows and doors** to limit smoke entry.

Please seek immediate medical attention for worsening symptoms such as chest discomfort, shortness of breath, severe coughing or wheezing, dizziness, or any worsening of mental health.

**The best way to protect your health
is by reducing exposure to wildfire smoke.**

COMMUNITY PLANNING FOR WILDFIRE SMOKE

Preparing for Wildfire Smoke

- **Collaborate** with local emergency staff, health authorities, or community volunteers to **tailor emergency plans** that include considerations for wildfire smoke safety in ways that reflect local needs and resources.
- **Support community gathering centres** including schools, childcare centres, care homes, and health centres in creating smoke resilience plans to reduce exposure during smoke events (see ASHRAE Guidelines for sample smoke resilience plans).
- **Establish local air monitoring** by using tools like the [WeatherCAN app](#) or [PurpleAir](#) to track air quality in real time. Air quality alerts may not always reflect current conditions of the geographic location. If air quality reports are not accurate to the community, consider installing a local air quality monitor - ideally both indoor and outdoor - at a communal gathering space or public space.
- **Raise awareness and share resources** to reduce smoke risks and inform community members of designated cool & clean air spaces, if available.

Responding During Smoke Events

- **Establish cool & clean air spaces** that are protected from smoke intrusion by:
 - Closing windows and doors (if extreme heat is not present)
 - Blocking drafts with towels, tape, or plastic sheeting.
 - Using portable HEPA air purifiers or building a [DIY box fan filter](#).
 - Using MERV 13 + and carbon filters to reduce odour and particulate pollutants.
 - Spaces may also be equipped with bottled water, chairs and blankets, fans and A/C units, and information about extreme heat and smoke safety.
- **Assist community members** who may not be able to reach clean air spaces or collect equipment on their own by arranging delivery through local staff, health teams, or community volunteers where possible.
- **Conduct wellness checks** by phone or in person, particularly on older adults, people living alone, or those with pre-existing health concerns. Communities may use the check-in to ensure they have access to supplies, clean air spaces, or health services.

HOUSEHOLD PLANNING FOR WILDFIRE SMOKE SAFETY

Preparing for Wildfire Smoke

- **Monitor air quality:** to monitor current or forecasted air quality near you, useful resources include:
 - Weather forecast apps, available on most mobile devices.
 - [WeatherCan App](#) for real-time updates and alerts.
 - [FireSmoke Canada](#) for smoke forecasts.
 - [Purple Air Monitor Maps](#) for localised, real-time air quality readings.
 - [BC Air Quality Warning Alerts](#) to subscribe to notifications during times of degraded air quality.



Please note: forecasts may not always accurately reflect local conditions. Trust your instincts! If smoke is visibly hazy and/or can be smelled, it is best to take precautions.

- **Set up a dedicated clean air room** like a bedroom or basement with intended protection from smoke.
 - Seal and close all windows and doors.
 - Block drafts with towels, tape, or plastic sheeting.
 - Use a HEPA air purifier or, if one is not accessible, consider building a [DIY box fan filter](#).
 - Use activated carbon filters to reduce gaseous pollutants.
 - Install MERV 13+ air filter to capture particulate matter.

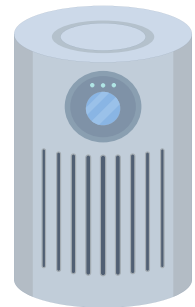

Staying Safe During Smoke Events

- Spend time in cool & clean air spaces whenever possible.
- Avoid outdoor exercise or strenuous activity when the air is smoky, especially for children, older adults, or people with pre-existing health conditions.
- Use a well-fitted N95 or KN95 mask when going outside during heavy smoke to reduce inhalation of fine particles (PM2.5).

WHAT TO DO WHEN THE AIR IS SMOKY



monitor
air quality
in the
area

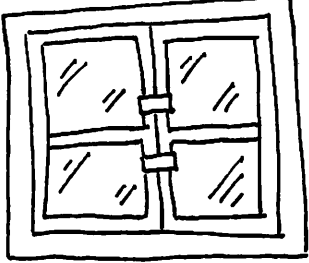

close
windows
and
doors

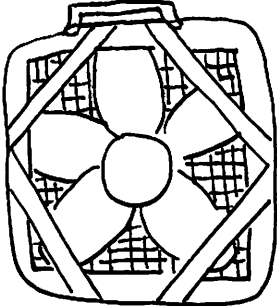

make an air filter...

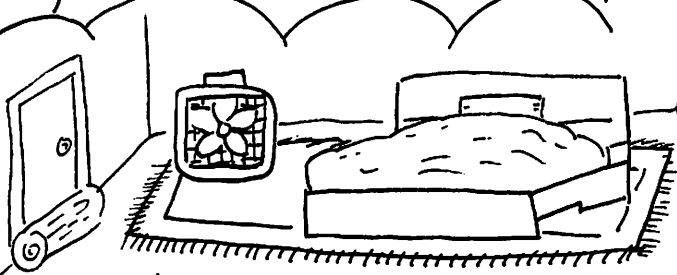

and use it in a 'clean air' room!



wear an N95 or
K95 mask if
you need to
go outside

Other Wildfire Smoke & Air Quality Resources

A public health companion for ASHRAE Guideline 44: Protecting building occupants from smoke during wildfire and prescribed burn events



Authors: National Collaborating Centre for Environmental Health
Published 2025.

This guide is a companion to a technical document for engineers and facility managers trying to keep indoor air clean during wildfire smoke events. It provides a guide for developing smoke-readiness plans for buildings. The checklists and one-page summary in the appendices may be particularly useful as a reference.

SFU BREATHE DIY Air Cleaners



Author: SFU BREATHE Project
Published 2024.

The BREATHE project helps communities prepare for wildfire smoke exposure and has published resources to help folks build their own air cleaners using a box fan, filter, duct tape, and scissors.

Housing, Building Materials, and Landscapes

Innovations in building materials and best practices can aid in designing more fire-resilient housing. This section covers information on those materials and best practices. Recognising that homes often extend beyond a human-constructed structure, it also includes resources with information about fire-resilient landscaping.



More information about climate-resilient building materials can be found on our [Building Materials project page](#)!

Material	Description	Fire Rating	Common Uses
Rammed earth	Compacted layers of earth.	4 hours	Infill walls with steel or timber framing. Load-bearing walls.
Straw bale	Dry grain stalk compacted into bales.	1-2 hours with plaster, 30 minutes without	Infill with timber or steel-frame walls.
Cob	Clay, straw, sand, water, and lime.	2-4 hours	Infill post and beam/timber-framing walls. Load-bearing walls.
Hempcrete	Blocks made from hemp, lime, and water.	1+ hours, depending on thickness	Infill walls with steel or timber framing.
Autoclaved aerated concrete (AAC)	Mineral-based block cured under high heat and pressure.	2-4 hours.	Load-bearing walls. Cladding.
Mass timber	Engineered wood bonded with adhesive or fastener.	3+ hour.	Load-bearing walls and structural elements (floors, roofs etc.)



Retrofits

Not building a new structure? Simple, relatively affordable retrofits like a fire-rated door, gutter guards, or an upgraded chimney can make a big difference. The cost estimates in this chart are based on desk research from 2025. Costs may vary greatly due to changes in the availability of materials, location, the cost of labour, and many other site-specific factors.

	Package A: More Affordable	Package B: More Expensive
Roof	 <p>Upgrade to Class A*-rated roofing materials, such as Class A-rated asphalt shingles. This is a straightforward upgrade and a great first step to replace multiple roofs.</p> <p>Estimated cost: \$4-7/square foot to replace. Higher costs for structural repairs. Labour and transport may add additional costs.</p> <p><i>*roof coverings are rated A, B, or C based on ability to withstand fire exposure. Class A roofing materials can withstand severe and potentially direct fire exposure with spreading flames.</i></p>	 <p>Upgrade to metal roofing. Metal roofing is non-combustible, highly durable, and ember-resistant. It may be a good long-term option for rural & remote communities because of its durability and low maintenance.</p> <p>Estimated cost: \$7-18/square foot to replace. Higher costs for a standing seam, which improves weather resistance.</p>
Walls	<p><i>Wall insulation tends to be a more expensive retrofit. Staged retrofits for higher priority homes may be more feasible. Funding programs for fire resilience and energy efficiency may be able to assist with costs.</i></p>	 <p>Improve wall insulation & continuous exterior insulation. Improved insulation assists in air sealing, which is beneficial for thermal performance and resilience, provided the cladding/sheathing used is non-combustible.</p> <p>Reliable cost estimates not available.</p>

Package A: More Affordable

Package B: More Expensive

Windows



Dual-pane tempered windows. Tempered windows with non-combustible frames will resist heat and reduce ignition risk.

Estimated cost: ~\$400/window. Target critical (i.e., highly-exposed) windows first to reduce initial costs.



Triple-pane tempered windows. Tempered windows with non-combustible frames will resist heat and reduce ignition risk. Triple-panes provided better insulation and noise reduction.

Estimated cost: ~\$1200/window. Target critical (i.e., highly-exposed) windows first to reduce initial costs.

Doors

Fire-rated exterior doors with good sealing. Replace doors that are combustible or hollow with solid-core or metal doors. Also double check that door frames are sealed. This retrofit has a good price to value ratio, as it significantly reduces ignition risk.

Estimated cost: \$295-500/door, varying based on the fire rating of the door, hardware used, and level of retrofit required.



Funding Opportunity! Both BC Hydro and Fortis BC offer rebates of up to \$2,000 for installing energy-efficiency doors and windows.

Gutters



Install gutter guards. Gutter guards can prevent debris accumulation, reducing the risk of ember ignition on roof edges.

Estimated cost: \$8-28/linear foot.



Install non-combustible gutters. In addition to gutter guards, gutters made of non-combustible material can further prevent ember ignition.

Estimated cost: \$15-40/linear foot for metal gutters, depending on the gutter type and material.

Package A: More Affordable

Package B: More Expensive

Vents

Ember-resistant vents, screens, and covers. Replacing standard vents with ember-resistant, fire-rated options is a high-impact and cost-effective option to retrofit older homes. Mesh screens blocking ember entry to attics and eaves can provide further protection.

Estimated cost: \$20/screen, varying based on the number and type of vents and whether vents are retrofitted or replaced, the latter being more expensive.

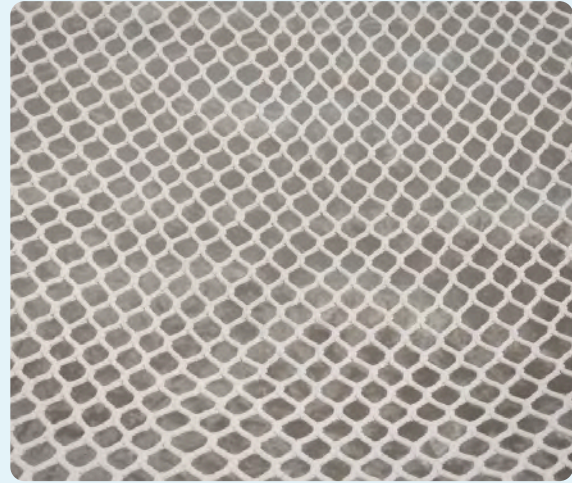

Chimney

Upgrade the chimney. Spark arrestors, non-combustible chimney caps, and screens can all mitigate and prevent ember entry. Chimney upgrades are also easy to service locally.

Estimated cost: \$250-1200/chimney, depending on the number of upgrades made.



Siding



Use non-combustible siding. Cement and cellulose fibre panels or planks have strong fire resistance, durability, and low maintenance requirements, but are quite heavy. Aluminum is a lighter and low-cost option.

Estimated cost: \$7-15/square foot to replace. Labour and transport may add additional costs.



Use non-combustible siding. Stone veneer is a more expensive option for non-combustible finishes.

Estimated cost: ~\$25/square foot.

Package A: More Affordable

Package B: More Expensive

Outdoors



Vegetation management. Thin combustible vegetation around the perimeter of the property or remove completely. For instance, trim trees and remove mulch. Keep the zone around the building free of combustible material.

Estimated cost: \$0.50-\$5/square foot, depending on if a contractor is used or if community volunteers are able to work together to protect homes.

Exterior sprinkler system. Install exterior sprinkler systems for wetting the perimeter or roofs in the event of a fire. Provide accessible water and hookups for local firefighting. Water availability can be limited in remote communities, which may require a portable system with its own emergency water tank.

Estimated cost: \$40-500+/property, depending on system complexity, permanence, type of sprinkler, and range.

Other Resources for Fire-Resilient Housing

FireSmart Residential Development Guide Best Practices for Planning, Design, and Construction



Authors: FireSmart Canada™
Published 2025.

This document is based on the FireSmart Development Planning and Design Best Practices and the NRC-National Guide for Wildland-Urban Interface Fires. It shares principles and best practices for planning, design, and construction of homes to make them more resilient to wildland fires. Example diagrams are provided in the Appendix (page 21 onwards).

Village of Lytton - Fire Resilient Community Fact Sheet



Author: Village of Lytton
Published 2024.

This is a one-page list of recommendations related to landscaping and building to reduce the risk of fire spread and damage, building from the Village's experience with a destructive wildfire in 2021.

The right column is focused on building recommendations, while the left is about landscaping.

West Coast Building Standard: Residential Construction Specifications



Author: Richard Hall, Nuxalk Nation Housing Specialist and Advisor
Published 2023.

Developed as part of the Nuxalk Nation's Housing Initiative, this building design guide provides solutions for affordable, energy-efficient homes for coastal areas where buildings need to be resilient to rain, moisture, and other coastal climate hazards. The guidelines lead to units that are energy-efficient to a minimum of Energy Step Code 3, which means they are 20% more efficient compared to the baseline requirements of the BC Building Code. The standard also includes culturally appropriate features, such as a shared cultural kitchen for canning, skinning, and weaving.

A series of six short videos - Richard & Friends - that complement this publication is available on the [BCIT website](#).

FireSmart Fact Sheet: Siding



Author: FireSmart Canada
Published 2022.

Exterior walls - siding - are a fire safety risk because damage to siding can allow fires to reach underlying walls and penetrate a building's interior. This one-page document provides guidelines for those who are considering renovating siding to promote fire resilience.

FireSmart has also produced a [more comprehensive home development guide](#) that recommends designs, materials, and practices to reduce a building's vulnerability to wildfire.

Cool Roofs and Walls to Reduce Heat Gain



Author: Building America Solution Centre, Office of Energy Efficiency & Renewable Energy
Published 2023.

'Cool' roofs or walls use materials or coatings that stay relatively cool when the sun shines directly on them, which reduces heat conducted into the building. Cool roofs and walls improve comfort and energy efficiency, especially during periods of extreme heat.

Climate zones are only mapped for the United States on the website. BC's climate zones can be found on [Better Homes BC](#).

Three Steps to a Cost-Effective FireSmart™ Home



Author: Intact Centre on Climate Adaptation at the University of Waterloo
Published 2023.

This document provides guidance on landscaping and home upgrades that improve a home's fire resilience, including options that do not require working with a contractor and can be done by a resident and/or their community.

The low-cost options in step 1 are related to landscaping and home maintenance.

